

INFRARED RECEIVER MODULE

紅外線接收模組

Part Number: T3800M

Package outlines

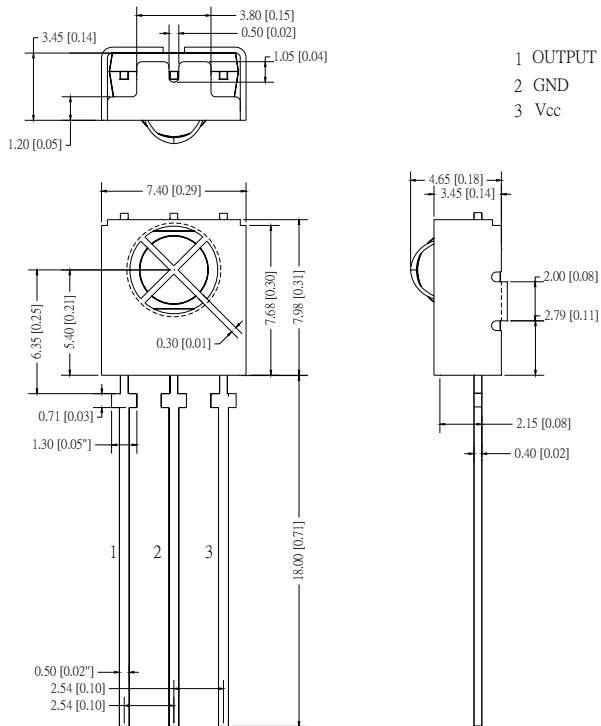

1 . Features :

- 1) Miniature size
- 2) Built-in exclusive IC
- 3) Wide half angle long reception distance
- 4) High immunity against ambient light
- 5) High protection ability to EMI
- 6) Wide voltage

2 . Applications :

- 1) AV instruments (Audio, TV, VCR, CD)
- 2) Home appliances (Air-conditioner, Fan, Light.)
- 3) Remote control for wireless devices

ITEM	MATERIALS
Resin	Epoxy
Bonding Wire	1.0mil Au
Lens color	Black
Lead frame	Ag plating iron alloy
PD	Silicon

NOTES:

1. All dimensions are in millimeters (inches);
2. Tolerances are $\pm 0.25\text{mm}$ (0.01inch) unless otherwise noted.

Rev :	Date	Drawn by :	Checked by :	Approved by :
A				

INFRARED RECEIVER MODULE

紅外線接收模組

Part Number: T3800M

Absolute maximum ratings

($T_A=25^{\circ}\text{C}$)

Parameter	Symbol	Value	Unit
Power voltage	Vcc	6.0	V
Operating Temperature	Topr	-10~+60	$^{\circ}\text{C}$
Storage Temperature range	Tstg	-20 ~+80	$^{\circ}\text{C}$
Soldering Temperature	Tsol	260 $^{\circ}\text{C}$ for 5 SEC (5mm [0.20"] from body)	

Electro-optical characteristics

($T_A=25^{\circ}\text{C}$)

Parameter	Test Condition	Symbol	Value			Unit
			Min	Typ	Max	
Supply voltage		Vcc	4.5	-	5.5	V
Supply Current	Input Signal=0	Icc	-	-	0.8	mA
Reception Distance	IV=5.0mW Vcc=5.0V	D	6	-	-	m
Half Angle		$\Delta\theta$	-	90	-	deg
B.P.F.Center Frequency		Fo	-	37.9	-	KHZ
Peak Wavelength		λ_p	-	940	-	nm
High Level Output Voltage		Voh	VDD-0.3	-	-	V
Low Level Output Voltage		Vol	-	-	GND+0.3	V
High Level Pulse Width	Burst Wave =600 μs	Twh	400	600	800	μs
Low Level Pulse Width		Twl	400	600	800	μs

INFRARED RECEIVER MODULE

紅外線接收模組

Part Number: T3800M

Reliability Test Items

Test Items	Test Conditions	Note	Ratings
Temperature Cycle	-40°C 30min ↑↓ 85°C 30min	100 cycle	0/22
Thermal Shock	-40°C 30min ↑↓ 100°C 30min	100 cycle	0/22
High Temperature High Humid Storage	T _a =85±5°C RH=85±10%	1000 hrs	0/22

Testing Method

Distance between emitter and detector specifies maximum distance that output waveform satisfies the standard under the conditions below against the standard transmitter

FIG-1

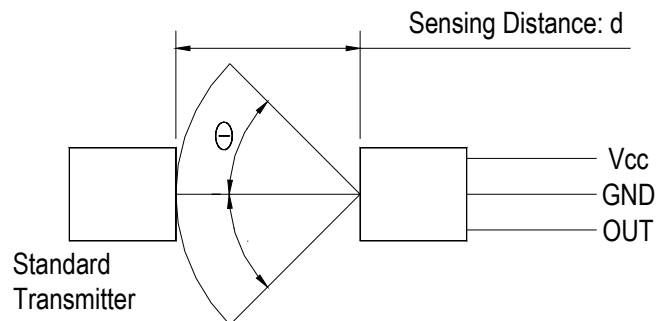

1) Measuring place

Indoor without extreme reflection of light

2) Ambient light source

Detecting surface illumination is 200 ± 5 Lux under ordinary white fluorescence lamp of no high frequency lightning

3) Standard transmitter

Transmitter wave indicated in FIG-2 of standard transmitter is arranged to satisfy 7mW under the measuring circuit specified frequency lightning .

FIG-2

