

悅達電子有限公司

YETDA INDUSTRY LIMITED

香港九龍旺角西洋菜街 1A 號百寶利商業中心 1101-1102 室  
 Rm. 1101-1102, 11/F, Pak Po Lee Comm. Centre,  
 1A Sai Yeung Choi Street, Mongkok, Kowloon, Hong, Kong.  
 Tel: (852)27701488 Fax: (852)23857771

## HRM-3800-T

### Description

The HRM-3800-T series are miniaturized receivers for infrared remote control systems. PIN diode and preamplifier are assembled on lead frame, the epoxy package is designed as IR filter.

The demodulated output signal can directly be decoded by microprocessor. The main benefit is the reliable function even in disturbed ambient and the protection against uncontrolled output pulses.

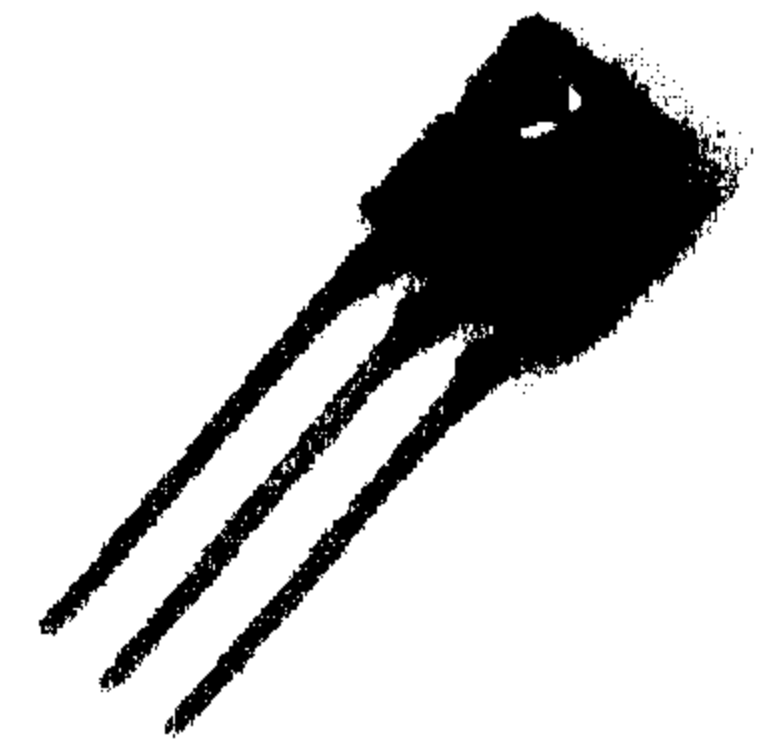

### Features

- Photo detector and preamplifier in one package
- Internal filter for PCM frequency
- TTL and CMOS compatibility
- Output active low
- Improved shielding against electrical field disturbance
- Suitable burst length  $\geq 10$  cycles/burst
- Enhanced data rate of 2200 bit/s

### Special Features

- High immunity against all kinds of disturbance light
- Best compromise between the number of transmittable IR codes and the disturbance suppression.
- No occurrence of disturbance pulsed at the output
- Supports most IR codes; see Table 4.

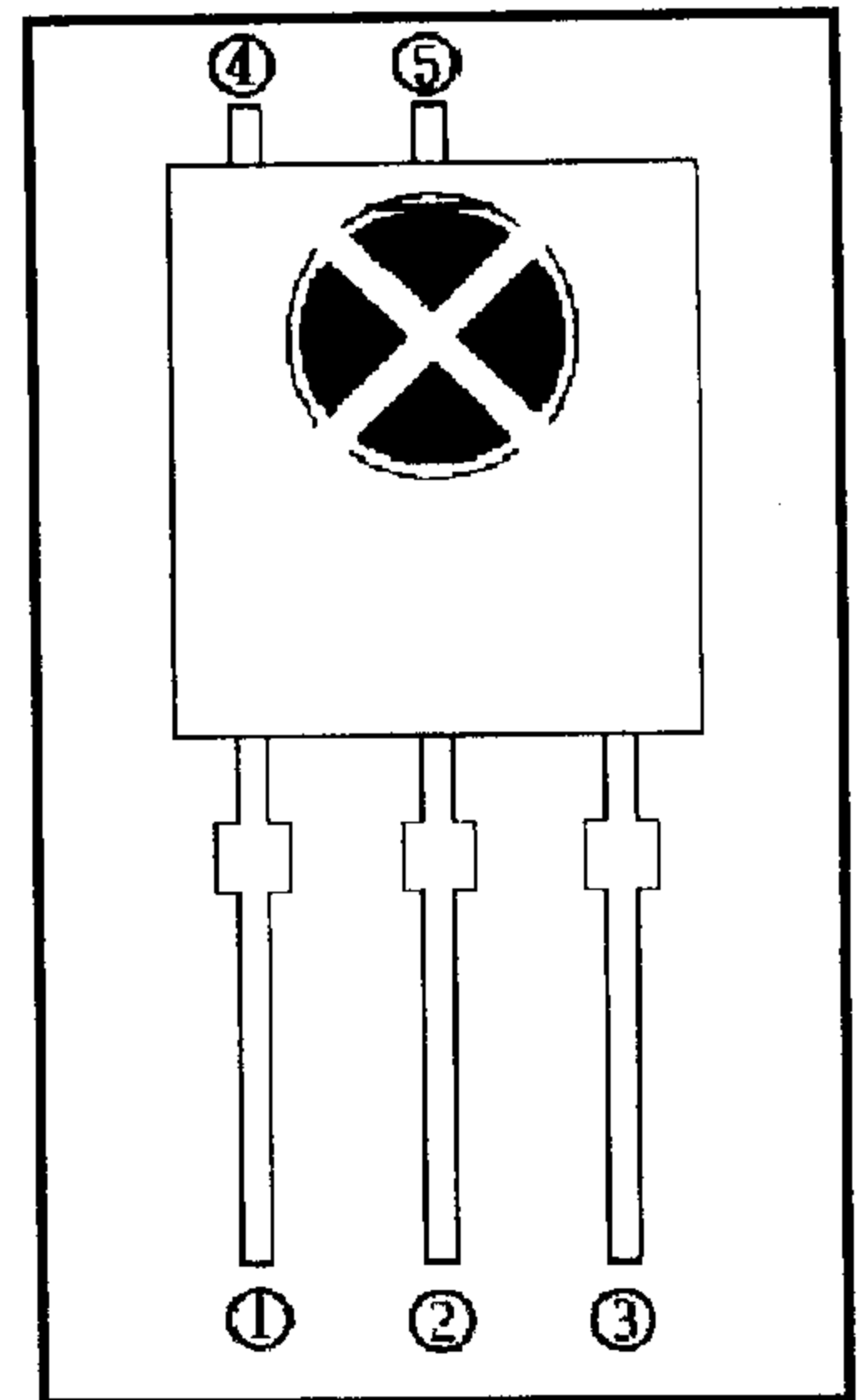

Fig.1

Pin No.	Pin Name	Description
1	Vout	Signal output
2	Gnd	Ground
3	Vin	Positive power supply
4	---	No Use
5	Gnd	Ground

Table 1.

# Block Diagram

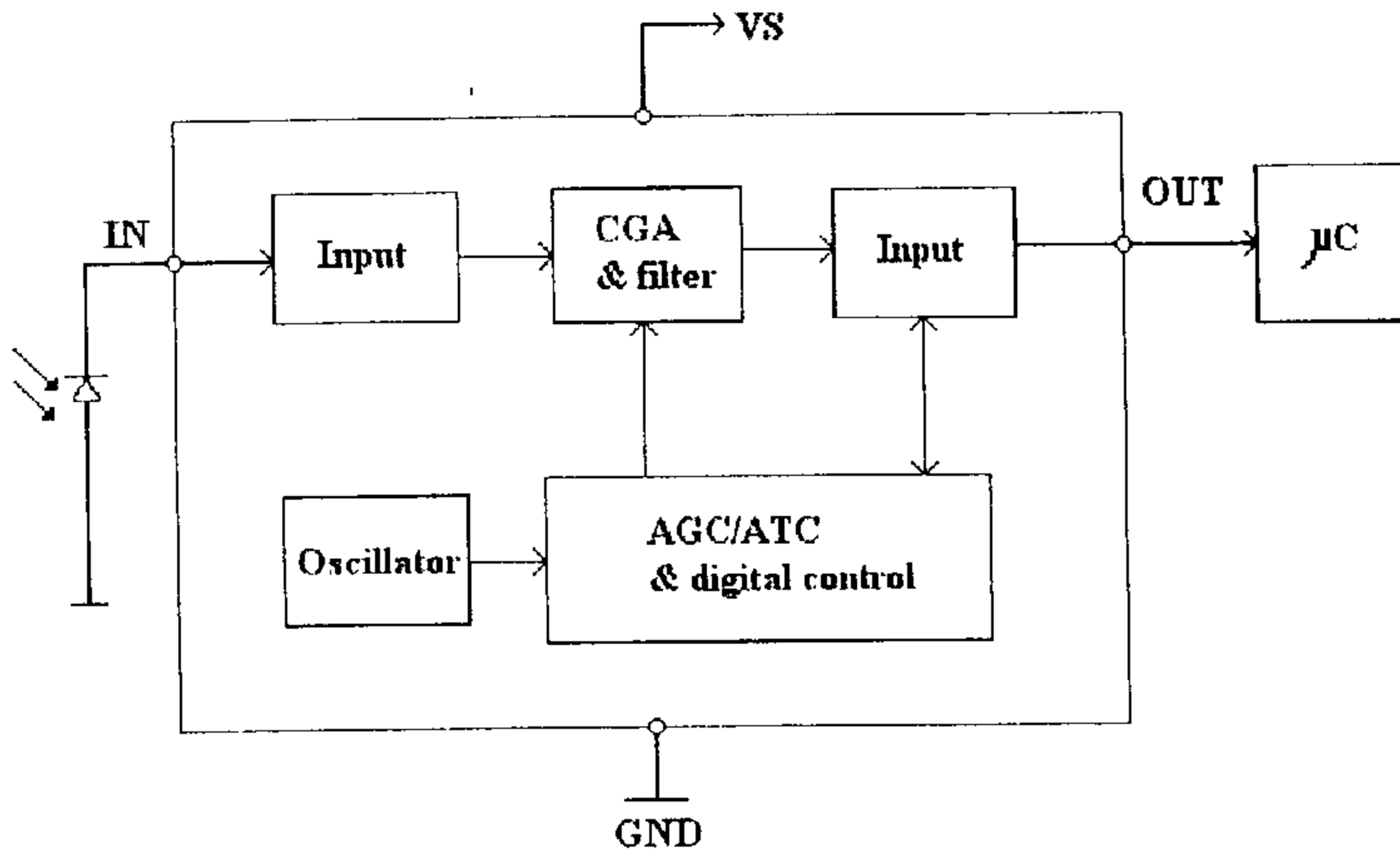

Fig.2

## Absolute Maximum Ratings

$T_a=25^\circ C$

Parameter	Test Conditions	Symbol	Value	Unit
Supply Voltage	( Pin 3 )	$V_s$	-0.3...6.0	V
Supply Current	( Pin 3 )	$I_s$	5	mA
Output Voltage	( Pin 1 )	$V_o$	-0.3...6.0	V
Output Current	( Pin 1 )	$I_o$	5	mA
Junction Temperature		$T_j$	100	$^\circ C$
Storage Temperature Range		$T_{stg}$	-25...+85	$^\circ C$
Operating Temperature Range		$T_a$	-25...+85	$^\circ C$
Soldering Temperature	$T \leq 5\text{sec}$ , 1 mm from case	$T_{sd}$	260	$^\circ C$

Table 2.

# Basic Characteristics

Ta=25°C

Parameter	Test Conditions	Symbol	Min.	Typ.	Max.	Unit
Supply Voltage ( Pin 3 )		Vcc	4.1	5	6	V
Supply Current ( Pin 3 )	Vs = 5 V , Ev = 0	IsD		1	1.5	mA
Transmission Distance	Ev = 0, test signal see fig.4, IR diode RY502IRA743, IF = 300mA	L	10	15		m
Output Voltage Low( Pin 1 )	IosL = 0.5 mA, Ee = 0.7 mW/m <sup>2</sup> , f = fo	VosL			250	mV
Irradiance ( 30 – 40 KHz )	Pulse width tolerance : Tpi – 5/fo < tpo < tpi + 5/fo, Test signal	Ee min		0.3	0.5	mW/ m <sup>2</sup>
Directivity	Angle of half transmission distance	φ 1/2		+ 45		deg
Response wavelength		λ p		940		nm
Tuning frequency		fo		38		KHz

Table 3.

- ※ 1. The burst waveform mentioned below is to be transmitted from standard transmitter  
measure the pulse width after 10<sup>th</sup> pulse from transmission.
- ※ 2.ON/OFF pulse width is to be satisfied within 0.5 cm ~ arrival distance.

## Cross-reference; IR codes to IR receiver type

IR Code	Grundig	NEC	RC5	RC6	RCMM	RCS-80	R-2000
Suppression	Good	Good	Good	Excellent	Excellent	Bad	Good

RCA	Sharp	Sony 12-bit	Sony 15-bit	Sony 20-bit	Zenith	High data rate
Good	Good	Good	Excellent	Excellent	Good	Bad

Table 4.

# Detection Length Test

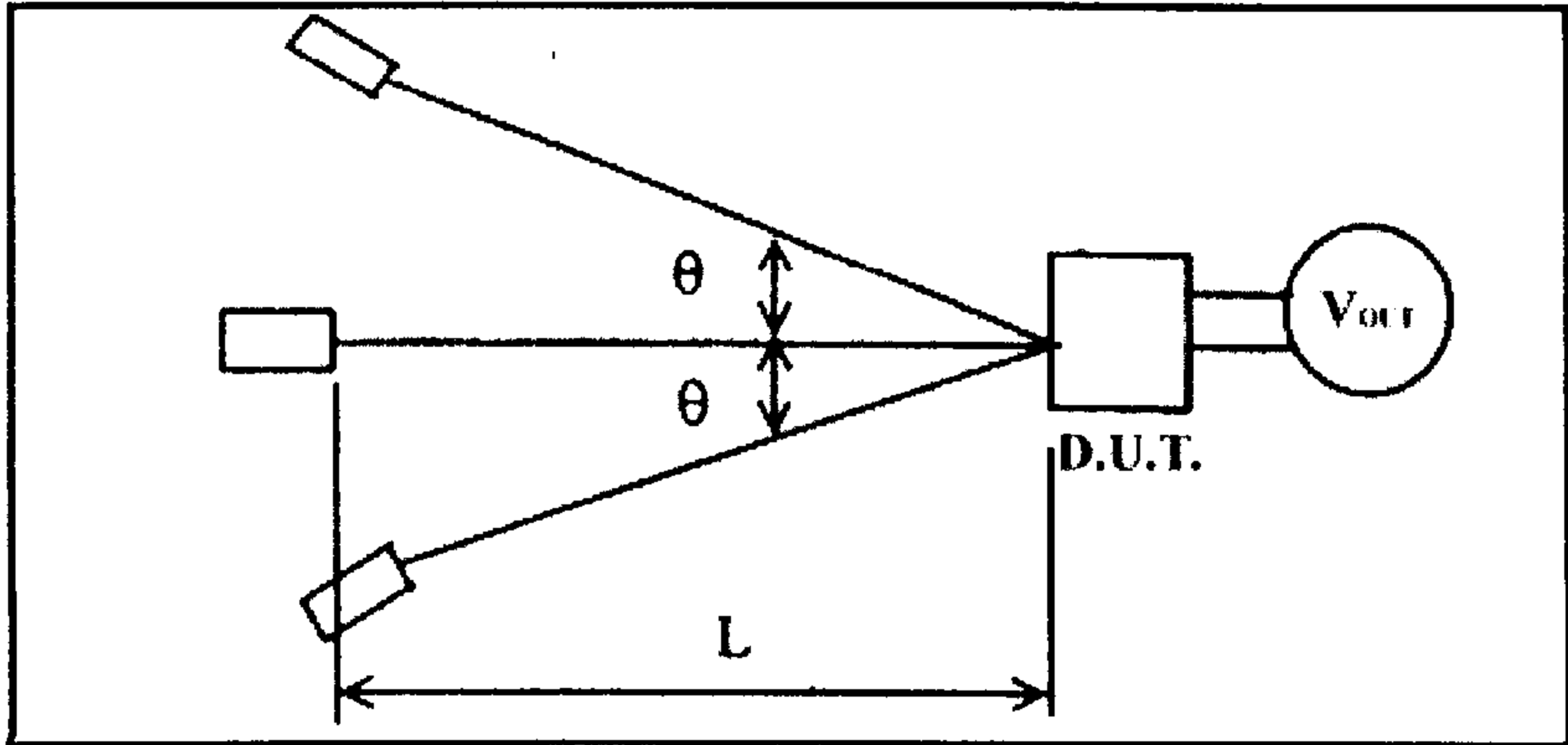

Fig.3

# Pulse Width Test

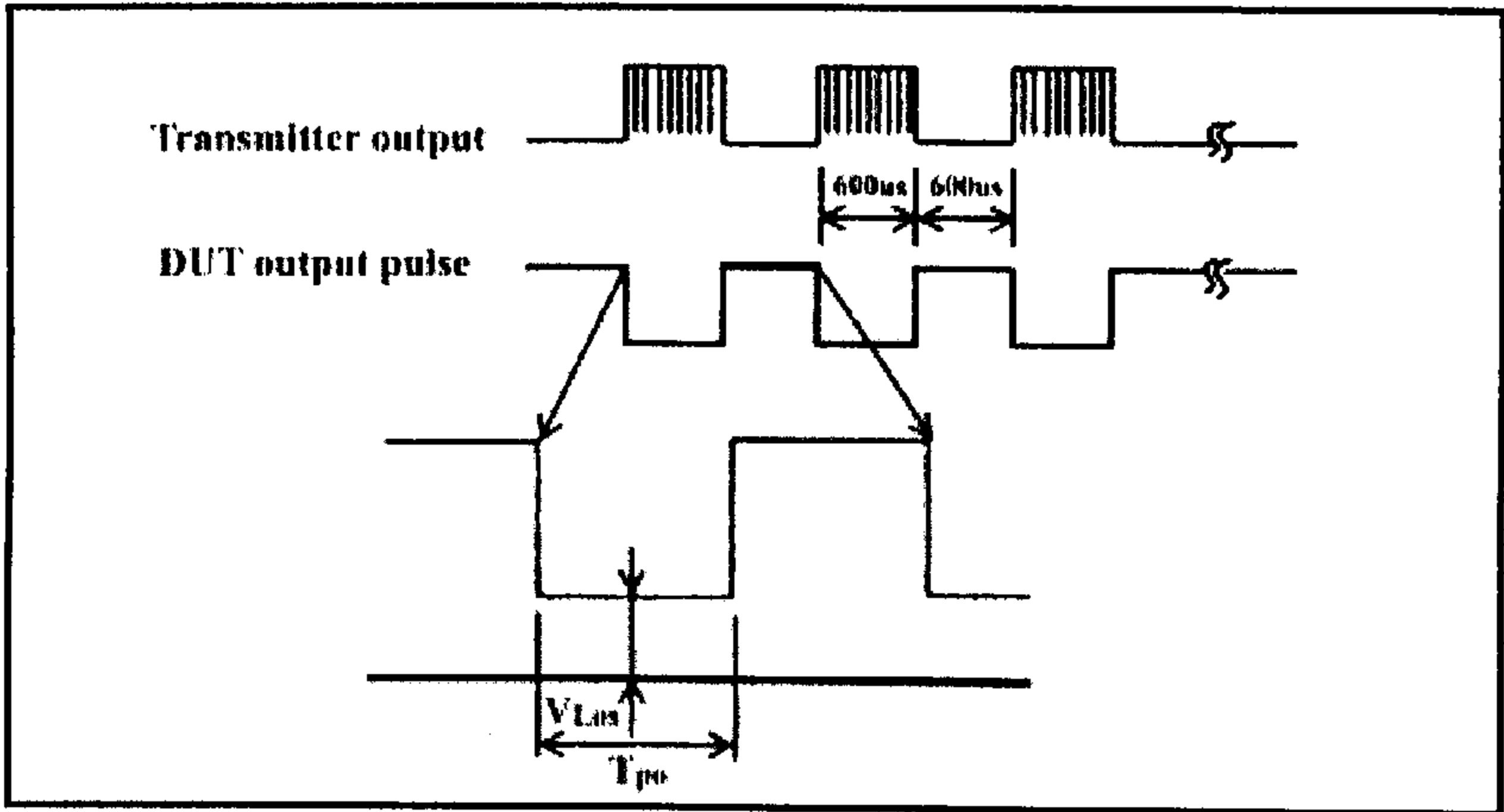

Fig.4

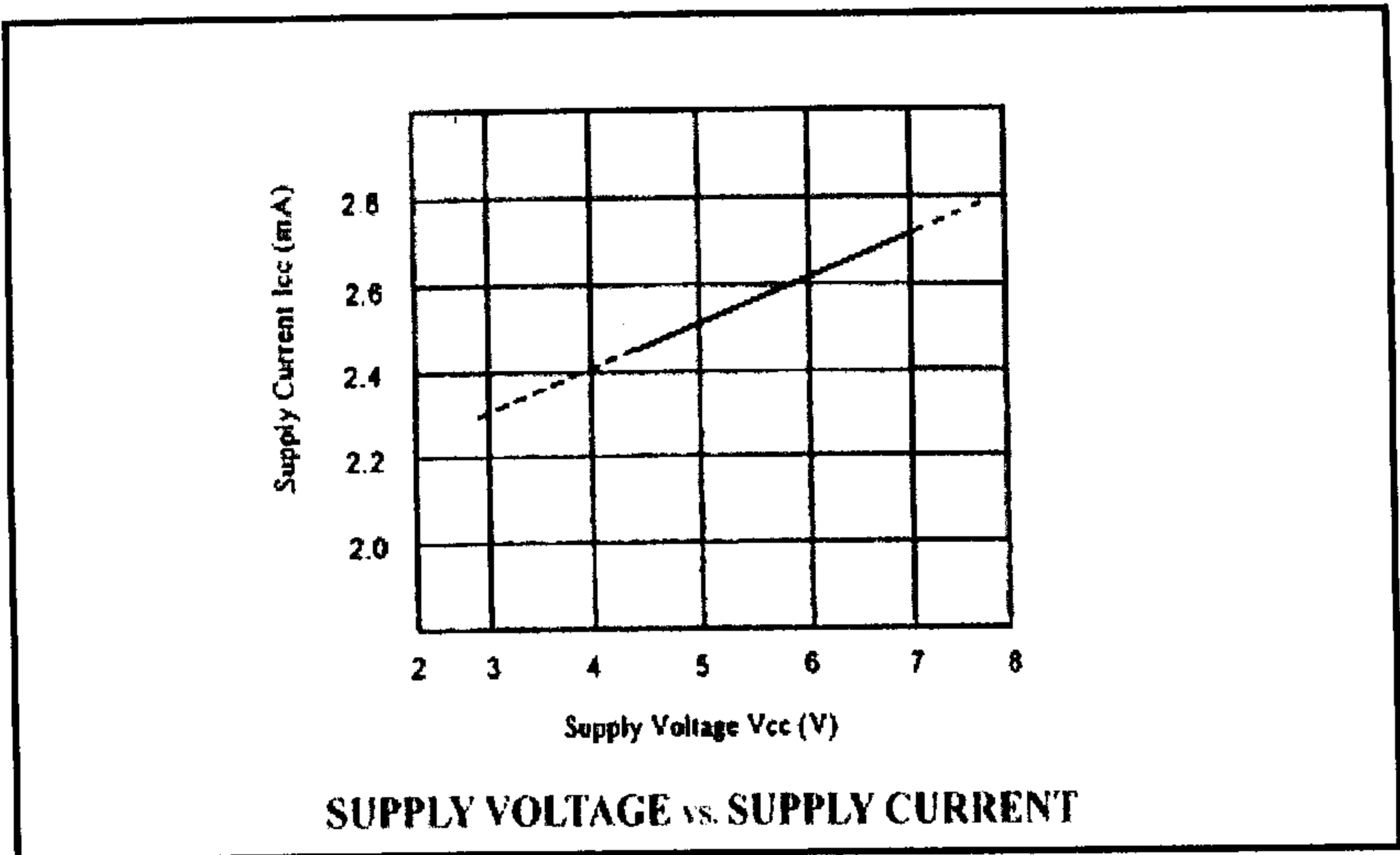

Fig.5

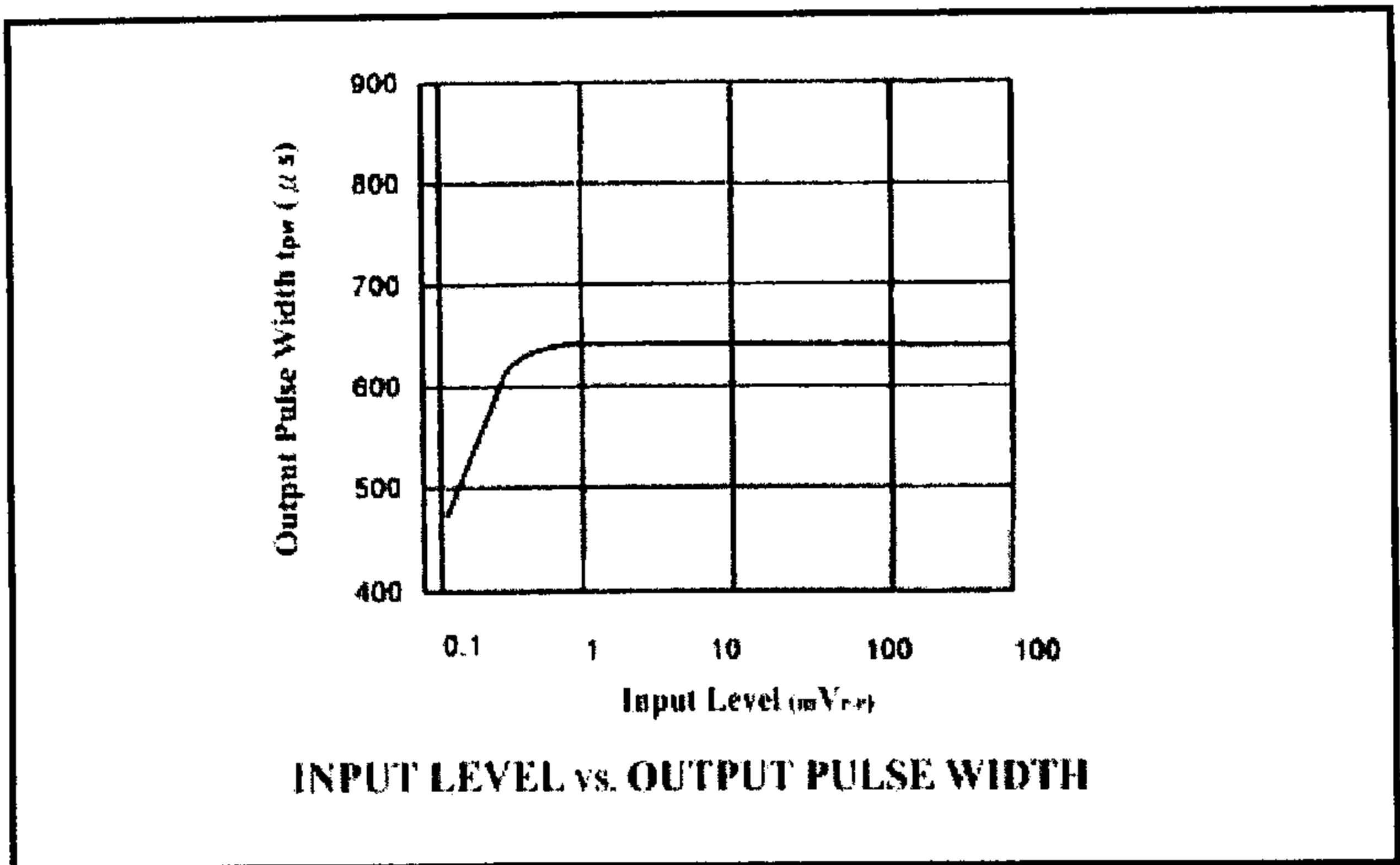
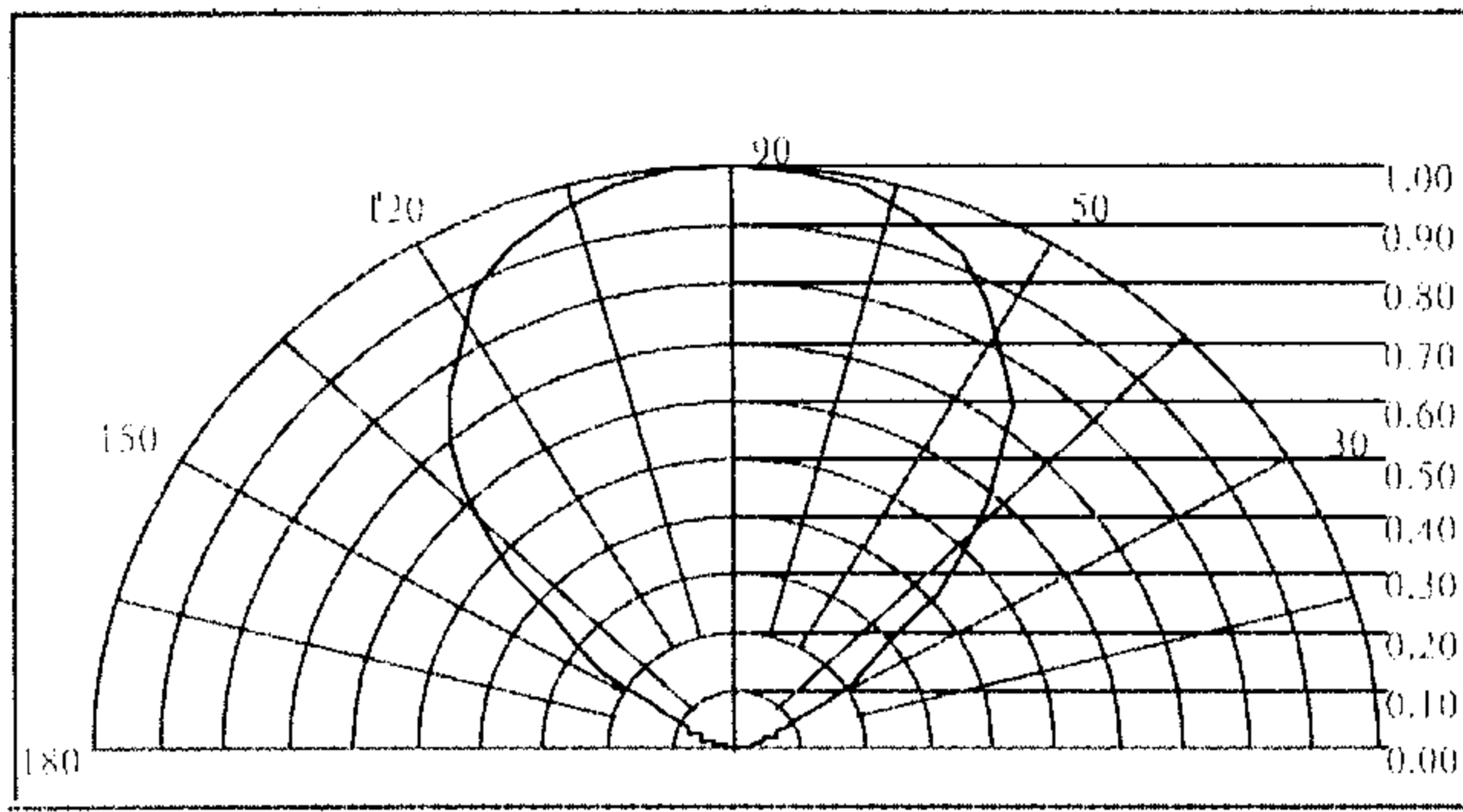

Fig.6



Sensitivity Angle ( Horizontal Direction ) Characteristics 【TYP.】

for reference

Fig.7

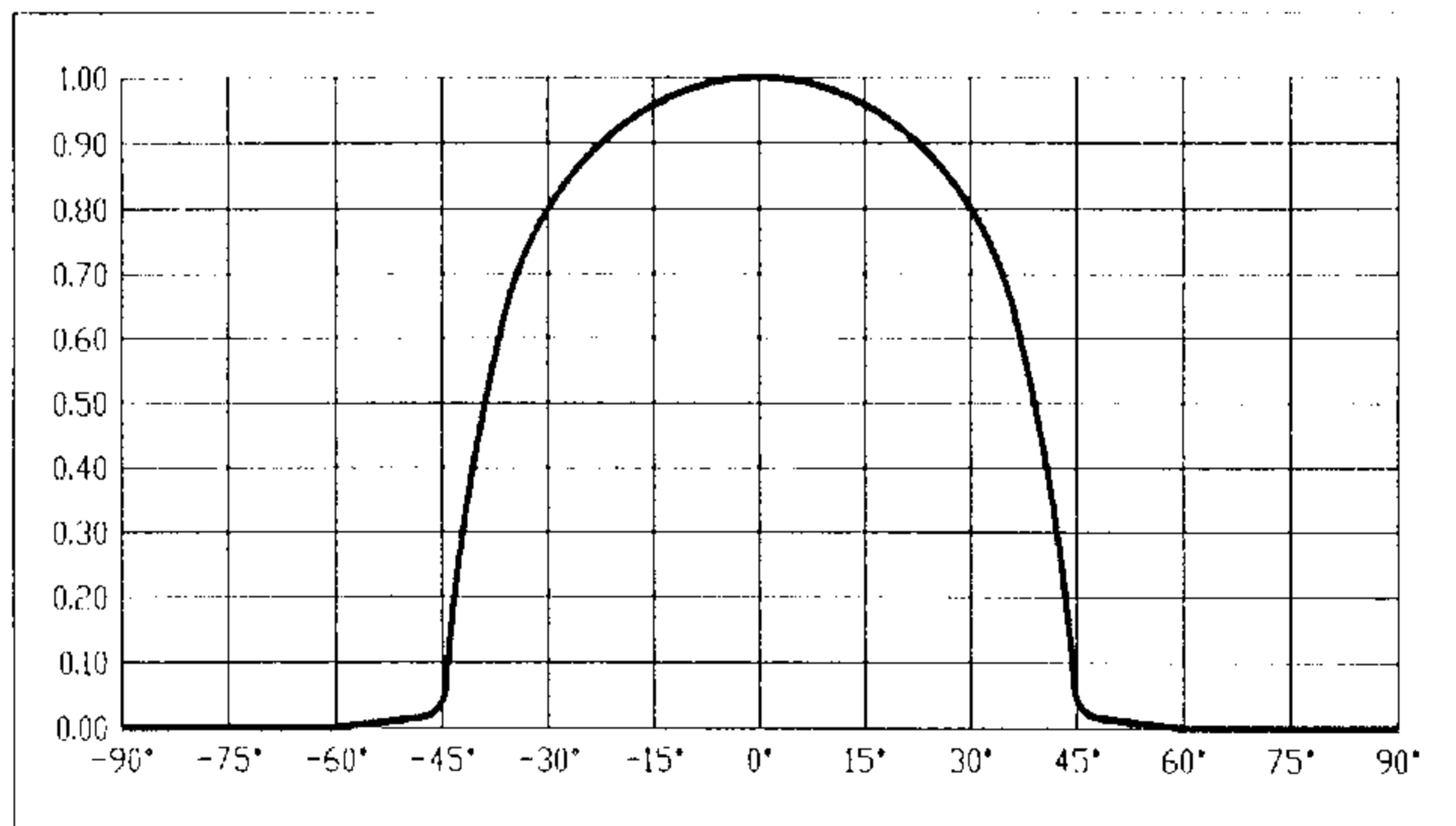

Fig.8

# Note

1. Distance between emitter & detector specifies maximum distance that output waveform satisfies the standard under the conditions below against the standard transmitter.
  - A. Measuring place .....Indoor without extreme reflection of light.
  - B. Ambient light source ... Detecting surface illumination shall be  $200 \pm 50$  Lux under Ordinary hit fluorescence lamp of no high frequency lightning.
  - C. Standard transmitter... Burst wave indicated in drawing pulse width test of standard Transmitter shall be arranged to 50mVp-p under the measuring circuit.
2. ( Electro-optical characteristics ) shall be satisfied after 2 hours in the normal temperature.
3. ( Electro-optical characteristics ) shall be satisfied and no conoid deforms and destructions of appearance ( excepting deforms of terminals ) .

## Precaution of Application

### Designing 1.Soldering pattern:

The dimensions of the recommended soldering pattern may not meet every user.  
Recommended soldering pattern is listed below.

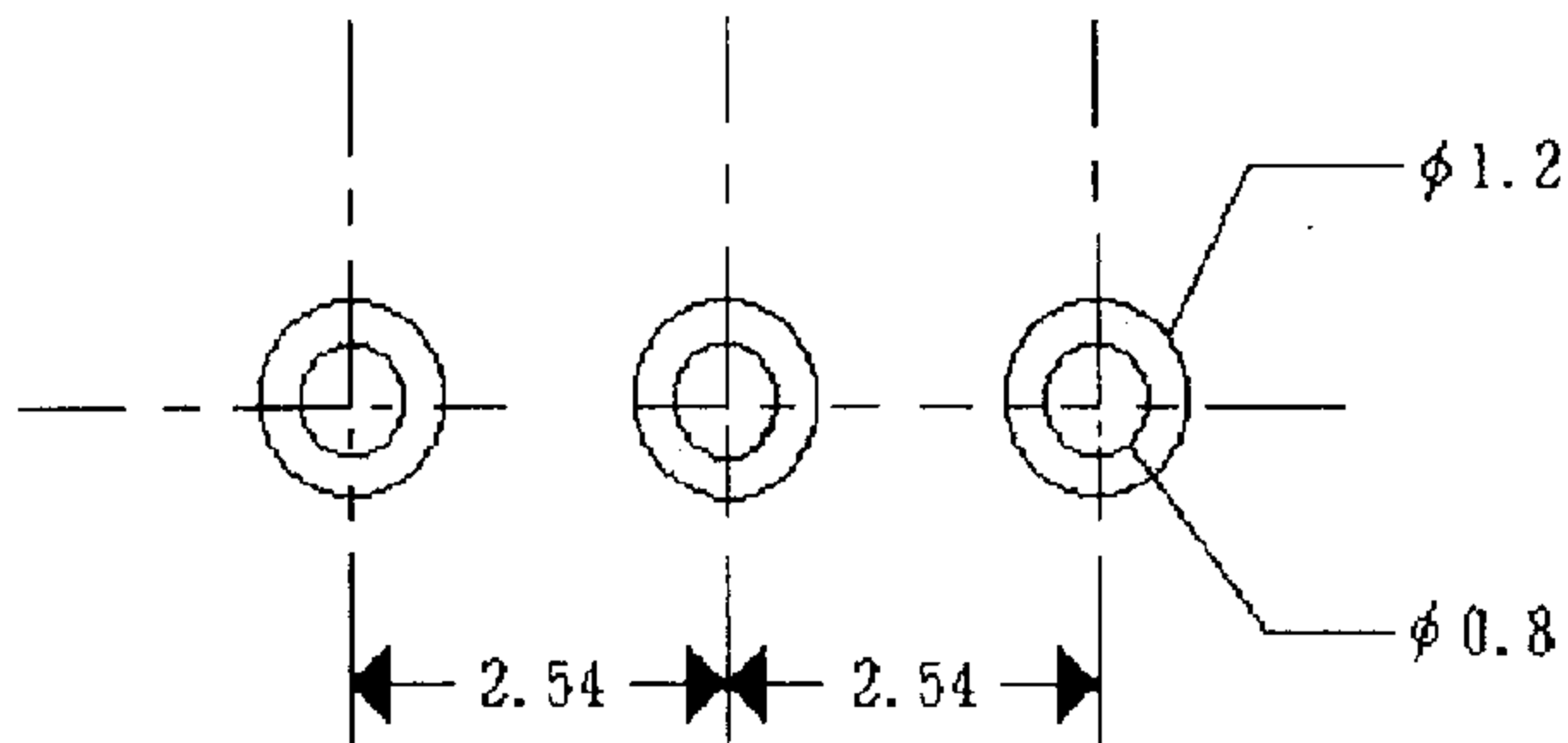

## Designing 2: Circuit layout

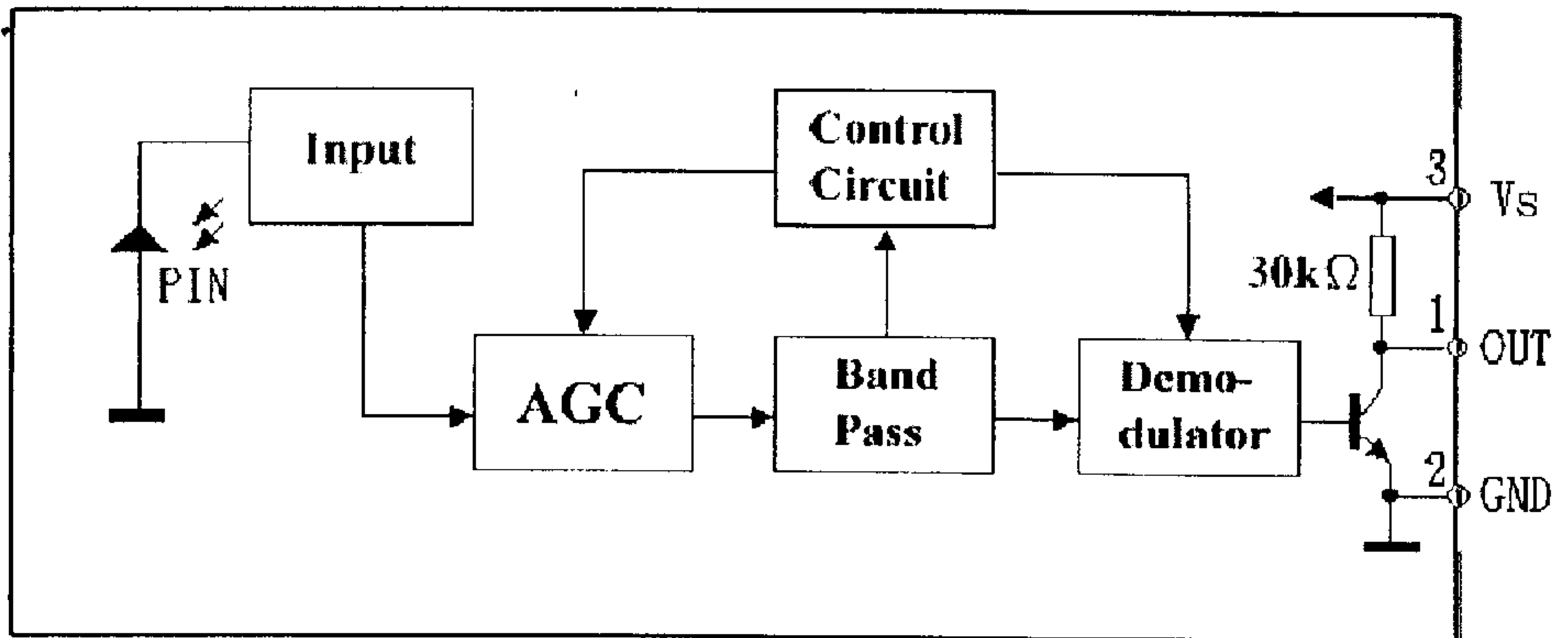

## Designing 3: Maximum Ratings.

Any application should refer to the specifications of absolute maximum ratings.

### Storage

- ◆ Recommended to Store the products in the following conditions is:
- ◆ Humidity: 60%RH Max.
- ◆ Temperature: 5°C~30°C
- ◆ Shelf life in sealed bag: 6month at < 40°C and < 90%RH.
- ◆ After the bag is opened, devices that will be subjected to solder, or equivalent processing must be:

**Mounted within 1 year at factory conditions of  $\leq 30^{\circ}\text{C}$  @ 60%RH**